



JUNTAS DE DIRECCIÓN



JUNTAS NACAM DIAMETRO DE GIRO EXT. Ø 42

CON PINZAS	Acoplamiento	Tipo	Referencia	Tipo	B	X1
	15	C1	0734	SIMPLE	39	
	15	C1	5118	DOBLE	39	50
	17	C1	0311	SIMPLE	39	
	17	C1	5126	DOBLE	39	50
	19	C2	0309	SIMPLE	39	
	20	C1	0839	DOBLE	39	
	20	C1	5119	SIMPLE	39	50
	20	C1	5152	DOBLE	38.75	66
	36 dientes 5/8"	C3	0265	SIMPLE	39	
36 dientes 5/8"	C3	5087	DOBLE	39	50	

PARA SOLDAR	17	C1	307	SIMPLE	31	
	18	C1	570	SIMPLE	31	
	20	C1	306	SIMPLE	31	

CON CRUZETA	20	C1	5107	SIMPLE	51	
	25	C1	5048	SIMPLE	72	
	30	C1	0886	SIMPLE	55	

C1		STANDARD: Ø 15 Ø 17 Ø 20
C2		STANDARD: Ø 19x14
C3		STANDARD: 26 dientes 5/8" 28 dientes/40 divisiones - 37 dientes 48 dientes 3/4" - 21 dientes
C4		STANDARD: 5 dientes/27

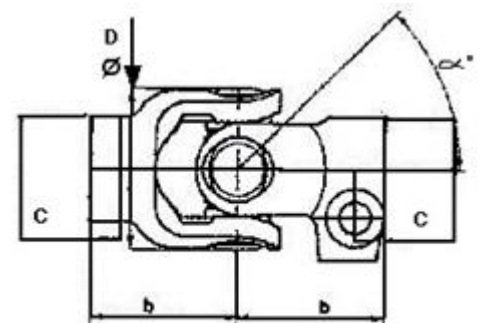

JUNTA SIMPLE CON ACOPLAMIENTO ABIERTO

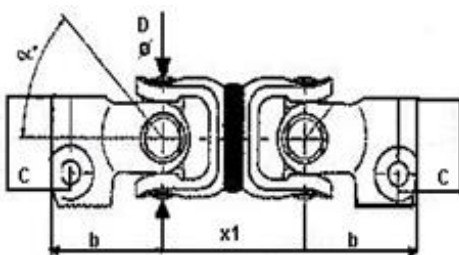

JUNTA DOBLE CON ACOPLAMIENTO ABIERTO

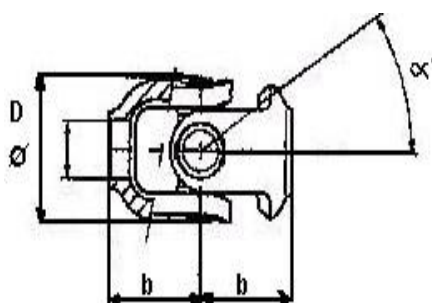

JUNTA SIMPLE PARA SOLDAR

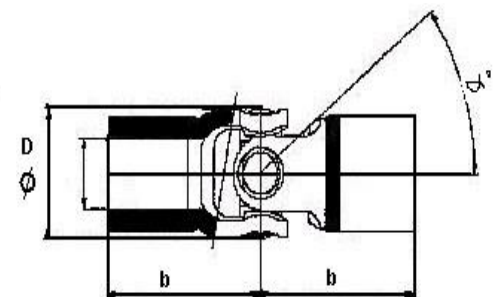

JUNTA SIMPLE A CRUZETA



JUNTAS NACAM DIAMETRO DE GIRO EXT. Ø 55

CON PINZAS	Acoplamiento	Tipo	Referencia	Tipo	B	X1
	25	C1	0947	SIMPLE	60	
	25	C1	5022	DOBLE	60	
	54 DIENTES	C3	5104	SIMPLE	60	
	75 DIENTES	C3	0638	SIMPLE	60	75
	79 DIENTES	C3	0639	SIMPLE	60	75
	79 DIENTES	C3	5125	DOBLE	60	75

PARA SOLDAR	22	C1	0244	SIMPLE	44	
	27	C1	5134	SIMPLE	44	

CON CRUCETA	30	C1	0291	SIMPLE	80	
-------------	----	----	------	--------	----	--

C1		STANDARD: Ø 25
C2		CONSULTAR
C3		STANDARD: 54 dientes 75 dientes – 79 dientes
C4		A CONSULTAR

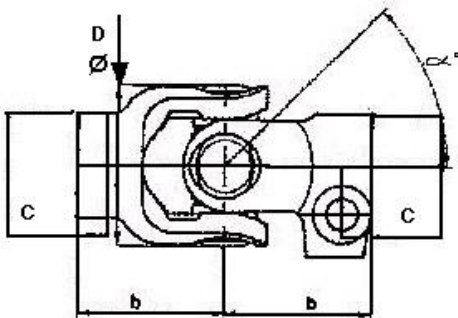

JUNTA SIMPLE CON ACOPLAMIENTO ABIERTO

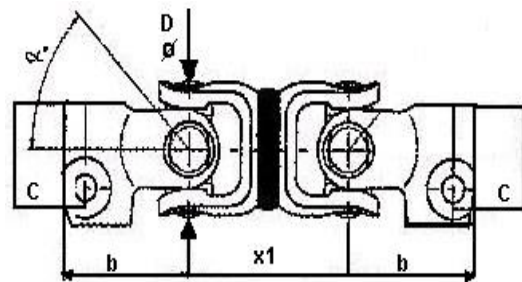

JUNTA DOBLE CON ACOPLAMIENTO ABIERTO

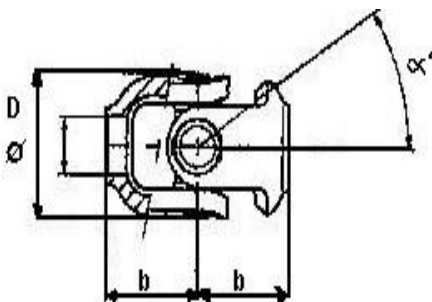

JUNTA SIMPLE PARA SOLDAR

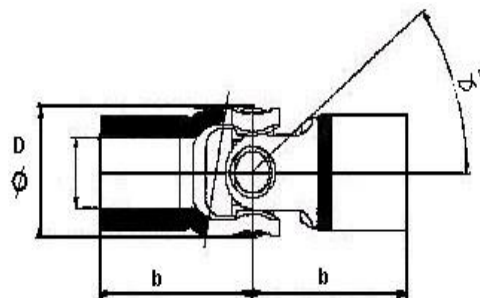

JUNTA SIMPLE A CRUCETA